

## Backflush filter

### R5-3

Variable segment cleaning with external medium, rated pressure up to 16 bar (232 psi)

Connection sizes: DN 65 to DN 200, cast design

#### 1. Features

##### Powerful, fully automatic filtration

- Used in shipping and industry
- Continuous filtration supports rational production processes
- Low backflush flow rates and optimal cleaning of the filter element improve filtration efficiency
- Backflush nozzle positioned directly on the filter element guarantees maximum cleaning effectiveness
- Perfect synthesis of ecology and economy
- Mature engineering and robust design
- Compact design
- Filter ratings from 25 to 1000 µm absolute, other ratings on request
- Easy to service
- Worldwide network of distribution and service agents



## 2. Operating principle

- The fully automatic backflush process starts when a defined differential pressure is reached or after a settable time interval. In the standard version, the backflush filter is backflushed with external medium.
- A minimum operating pressure of 3 bar at the inlet of the external nozzle is required to achieve efficient backflushing.
- The difference between the overpressure in the external nozzle and the atmospheric pressure at the outlet of the flush pipe is used for backflushing.
- When the backflush start time, determined by the differential pressure or the time interval, is reached, the flush valve opens and the gear motor starts to turn the filter element positioned between the nozzles.
- As a result of the pump pressure, the external medium – or the process medium that has already been filtered – flows at high speed through the vertical slot in the external nozzle, which is located directly on the filter element. The impurities trapped in the filter are discharged from the system via the flush pipe when the medium flows through the wire cloth into the internal nozzle.
- The flush valve closes again when the filter element has been turned approximately 400°, so that the backflush process is completed in only a few seconds.
- Since the element is turned, only the part covered by the cleaning nozzle is actually cleaned; the remainder can continue to be used for filtration → operation is not interrupted.

## 3. Technical Data

Connection:	DN 65 to DN 200
Material:	Nodular cast iron 40/0.7040
Max. operating pressure:	16 bar
Test overpressure:	32 bar
Max. operating temperature:	180 °C
Filter element:	Screen basket with wire cloth (smooth or pleated), perforated sheet (profiled), screen sieve
Filter rating:	25 to 1000 µm absolute, other ratings on request

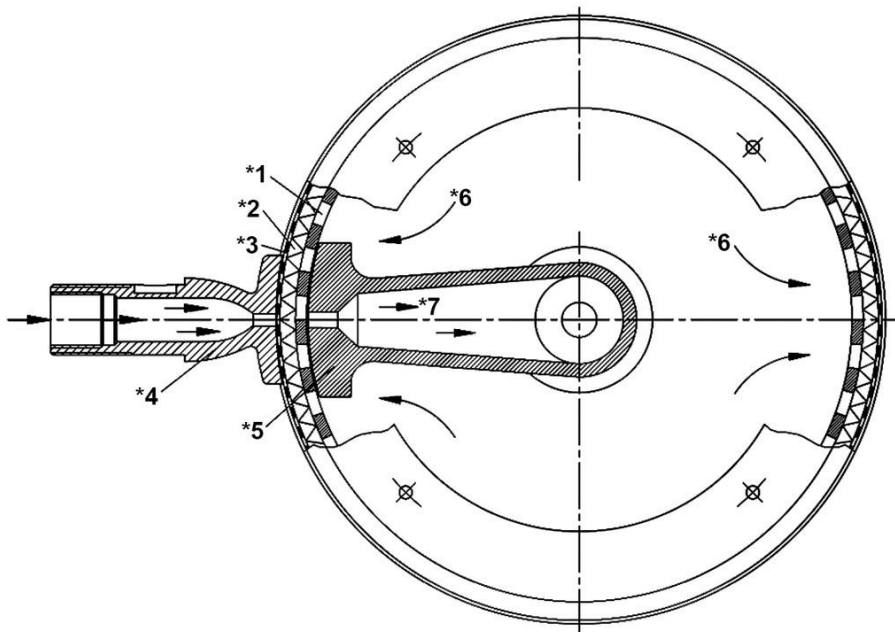

- \*1 = Body
- \*2 = Pleated wire cloth cylinder
- \*3 = Support cylinder
- \*4 = External nozzle
- \*5 = Internal nozzle
- \*6 = Flow direction (dirt side)
- \*7 = Flush flow rate

## 4. Dimensions

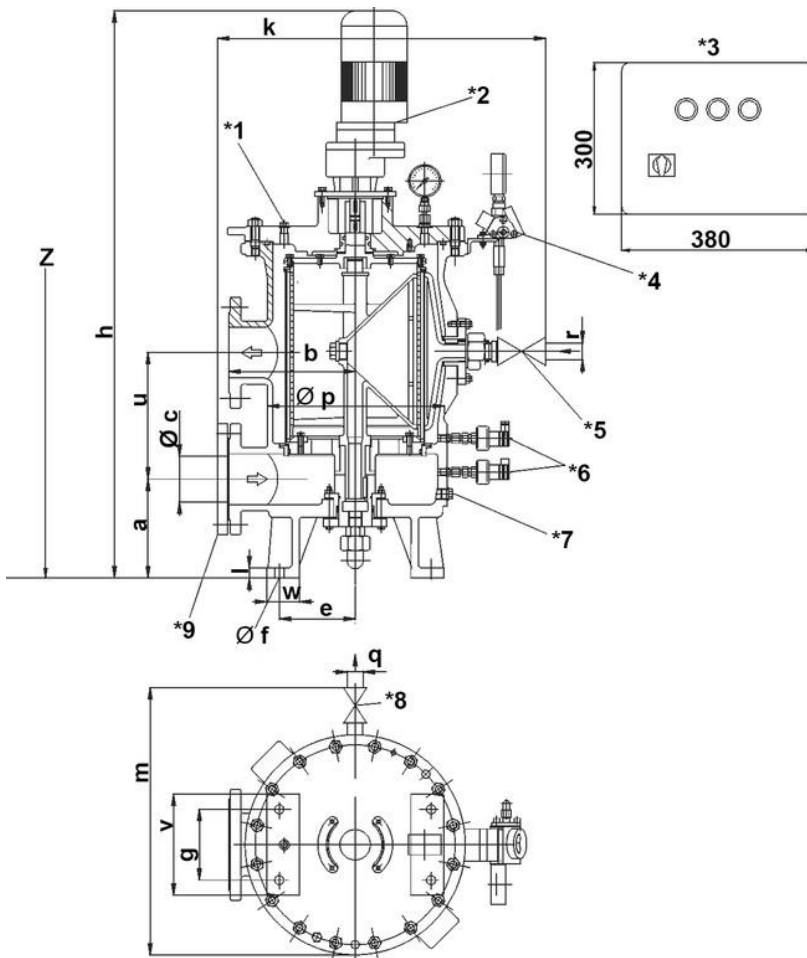

- Z = Clearance required
- \*1 = Vent G $\frac{1}{4}$
- \*2 = Motor
- \*3 = Switch box
- \*4 = Differential pressure indicator optional
- \*5 = Flushing medium inlet
- \*6 = Pressure transmitter
- \*7 = Drain G $\frac{1}{2}$
- \*8 = Flush pipe
- \*9 = Reducing mating flange

All dimensions except "q" and "r" in mm.

Type	DN	a	b	Ø c	e	Ø f	g	h	k	l	m	Ø p	q	r	u	v	w	Z	Capacity [l]	Weight [kg]
RR08W110G03	65*	130	160	77	123	14	100	900	450	12	480	270	G $\frac{1}{2}$	G $\frac{1}{2}$	190	160	41	920	19	130
RR09W110G03	80*	130	160	90	123	14	100	900	450	12	480	270	G $\frac{1}{2}$	G $\frac{1}{2}$	190	160	41	920	19	130
RR093110G20	80*	195	250	90	150	18	140	125	650	20	560	346	G $\frac{3}{4}$	G $\frac{3}{4}$	250	200	65	1260	45	225
RR103110G20	100	195	250	100	150	18	140	125	650	20	560	346	G $\frac{3}{4}$	G $\frac{3}{4}$	250	200	65	1260	45	225
RR113110G11	125	236	280	125	175	23	200	1300	760	20	650	400	G1	G1	270	260	62	1600	80	270
RR123110G21	150*	276	350	169	225	23	200	1421	820	20	740	516	G1	G1	350	280	65	1810	154	525
RR143110G21	200	276	350	200	225	23	200	1421	820	20	740	516	G1	G1	350	280	65	1810	154	525

\* Reducing mating flanges (DN 100, DN 125 and DN 200) to DIN 2501 PN 16 for DN 65, DN 80 and DN 150 connections.

## 5. Design and application

The design of the backflush filters is based on the respective customer's requirements. The material, type of construction and filter surface and rating are expertly adapted to the specific filtration task based on the medium and capacity.

The task can be optimised with the freely variable options available for the backflush filters.

### Options:

- **Heater**  
Capacity and size optimally matched to filter sizes.  
Steam and electric versions available.
- **Magnetic elements**  
Strong permanent magnets can be used.
- **Control**  
Control by means of a switch box with a programmable automation module.  
Easy parameterising with buttons and display.  
Programming and simulation on a PC.
- **Pressure transmitter**  
Differential pressure monitored with a pressure transmitter.  
This permits precise monitoring of the differential pressure using the PLC module in the switch box.  
Max. temperature: 150 °C  
Max. operating pressure: 40 bar  
Measuring tolerance: 0.3 %
- **Bypass filter**  
Manual, semi-automatic, fully automatic with change-over unit (manual, fully automatic).

Backflush filters are not at all complicated to use and they guarantee continuous filtration. The necessary steps are described in the following:

- The filter comprises a bowl with a cover and a gear motor.
- The bowl contains a vent port, a drain port and a filter element.
- The filter must be filled and vented before it is put into service. It must not be operated with the full pump flow when empty.
- Switch on the filter controller and start a flushing process with the hand release. If the viscosity of the medium is very sensitive to temperature, the filter controller should not be switched on until the filter reaches its normal service temperature.
- The filter controller must be switched off if the plant is not in service
- A minimum pressure of 3.0 bar at the inlet of the external nozzle must be present during the flushing process to ensure efficient backflushing.
- Backflushing starts automatically after a defined time or when the maximum differential pressure is reached. If the differential pressure exceeds 3 bar, the filter must be removed from service or changed over to bypass. Then dismantle the filter and clean the wire cloth cylinder (refer to "Cleaning").
- When a flushing process is tripped, the gear motor is switched on and the flush valve for the flushing medium inlet and outlet opens. The medium flows from the external nozzle through the filter element and into the internal nozzle as the element is turned by the motor.
- The flushing medium flows through the wire cloth at high speed, so that the contaminants trapped in the filter are detached and discharged via the flushing outlet and the flush pipe connected to it.
- The filter controller is programmed so that the flush valves close again and the gear motor is switched off after approximately 1¼ turns of the filter element.
- To clean the filter, switch off the filter controller, dismantle the gear motor, loosen the cover fixing screws and remove the cover. The complete filter element can now be lifted vertically out of the filter. To clean the filter element manually, spray it with steam, compressed air or water from the outside towards the inside. Pre-treat the element with a suitable solvent if the dirt cannot be removed easily. It may be necessary to dismantle the pleated wire cloth cylinder.

## 6. Type number key

### Type number key with selection example for R5-3 backflush filter DN 65 to DN 200

#### Main product group

R Automatic filter

#### Series

R Cast design

#### Inlet and outlet connections

08 Flange DN 65

09 Flange DN 80

10 Flange DN 100

11 Flange DN 125

12 Flange DN 150

14 Flange DN 200

#### Filter connection standard + rated pressure

3 EN 1092 PN 16 bar

W Flanges acc. to factory standard

#### Position of main connections

1 Above one another on the same side

#### Cover fastening

1 Stud bolts or hexagon screws

#### Options

0 Standard version

2 Electric cartridge heater

3 Steam/thermal cartridge heater

7 Version without non-ferrous metals

G Rubber coating

#### Type of inner assembly

G Inner assemblies for automatic filter with external medium

#### Inner assembly size

XX

#### Housing version

B Coated

#### Nozzle material

4 Cast bronze

#### Number for special types or design features

XX

10 Nominal diameter 150/200

R R 09 3 1 1 0 G 20 B 4 10

Filtration Group GmbH  
Schleifbachweg 45  
D-74613 Öhringen  
Phone +49 7941 6466-0  
Fax +49 7941 6466-429  
[industrial.sales@filtrationgroup.com](mailto:industrial.sales@filtrationgroup.com)  
[industrial.filtrationgroup.com](http://industrial.filtrationgroup.com)  
70381738.04/2020  
[Backflush filter R5-3](#)