

Dust filter cartridge

328 NZ

Ø 328 mm

1. Features

Star-pleated Filtration Group dust cartridges are used to separate dust from gases. Dusty air or gas is applied to the outside of the cartridges under pressure and the cleaned airflow exits at the top. The retained dust can be cleaned off with a rotating wing by means of a cleaning pulse or compressed air.

Regular and extensive performance testing of all materials used in production is the key to the consistently high quality of Filtration Group dust cartridges. Additional applications tests are carried out both on the test stands in our own development laboratory and on the customer's site. The results of these tests form the backbone of innovative products, mature production methods and unmatched operational reliability.

Characteristics

- High separation efficiency
- Uniform pleat distribution
- Reliable operation
- Large filter surface in a very small space
- Optimised filter materials
- Installation on the dirt side
- Worldwide sales



2. Technical Data

Material

Inner core:	Galvanized steel (standard) or stainless steel V4A
End caps:	Galvanized steel (standard) or stainless steel V4A
Seal:	Soft material PUR
Filter media:	Ti 07/1 - Electrostatic conductive polyester fleece with PTFE membrane Ti 08 - Electrostatic conductive polyester fleece, aluminium coated Ti 15 - Polyester fleece Ti 19/2 - Cellulose/polyester carrier with Polypropylen meltblown Ti 56/2 - Polyester fleece with PTFE membrane Ti 70 - Cellulose with 30 % polyester fibres Other filter materials on request

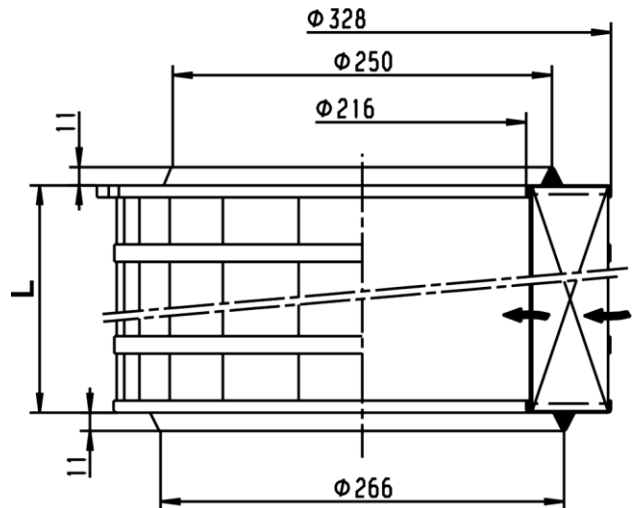

Cleaning

Nozzle:	RLD or MJD Rohgass
Cleaning pressure:	-3 bar to 4 bar, max. 4.5 bar (for RLD) -5 bar to 6 bar (for MJD)
Differential pressure:	max. 15 mbar

Technical data is subject to change without notice!

3. Order numbers

Order number	Type designation**	Length L [mm]	Filter media	Filter surface [m ²]	max. volume flow*** [m ³ /h]	max. operating temperature [°C]	Electro-static conductive
78388274	852 907 Ti 07-5	300	Ti 07/1	5	400	80	yes
78313124	852 907 Ti 15-5		Ti 15				no
78313249	852 907 Ti 70-6.3		Ti 70	6.3			no
79354770	852 908 Ti 07-7.5	600	Ti 07/1	7.5	750	80	yes
79354788	852 908 Ti 07-7.5 V4A*						no
79355447	852 908 Ti 08-10	600	Ti 08	10	750	80	yes
79354697	852 908 Ti 15-10		Ti 15				no
79354200	852 908 Ti 19-7.5	600	Ti 19/2	7.5	750	80	no
79354895	852 908 Ti 70-13		Ti 70	13			no
78361479	852 908 Ti 07-7.5 V4A Band*		Ti 07/1	7.5			yes
79355454	852 908 Ti 08-10 Band	600	Ti 08	10	750	80	yes
78312985	852 908 Ti 15-10 Band		Ti 15				no
78387979	852 908 Ti 19-7.5 Band		Ti 19/2	7.5			no
79355140	852 909 Ti 07-12.5	1000	Ti 07/1	12.5	1200	80	yes
79355181	852 909 Ti 19-12.5		Ti 19/2				no

* Version made of stainless steel V4A

** Further cartridge types available on request

*** These values may vary depending on the nature of the dust and the composition of the gas.

4. Installation

The dust filter cartridges (diameter: 328 mm) are fastened to the filter plate on the dirt side by means of a tie rod (tightening torque approx. 15 Nm).

A hole with a diameter of 214 mm must be drilled in the filter plate. Mounting is facilitated by a centre ring.

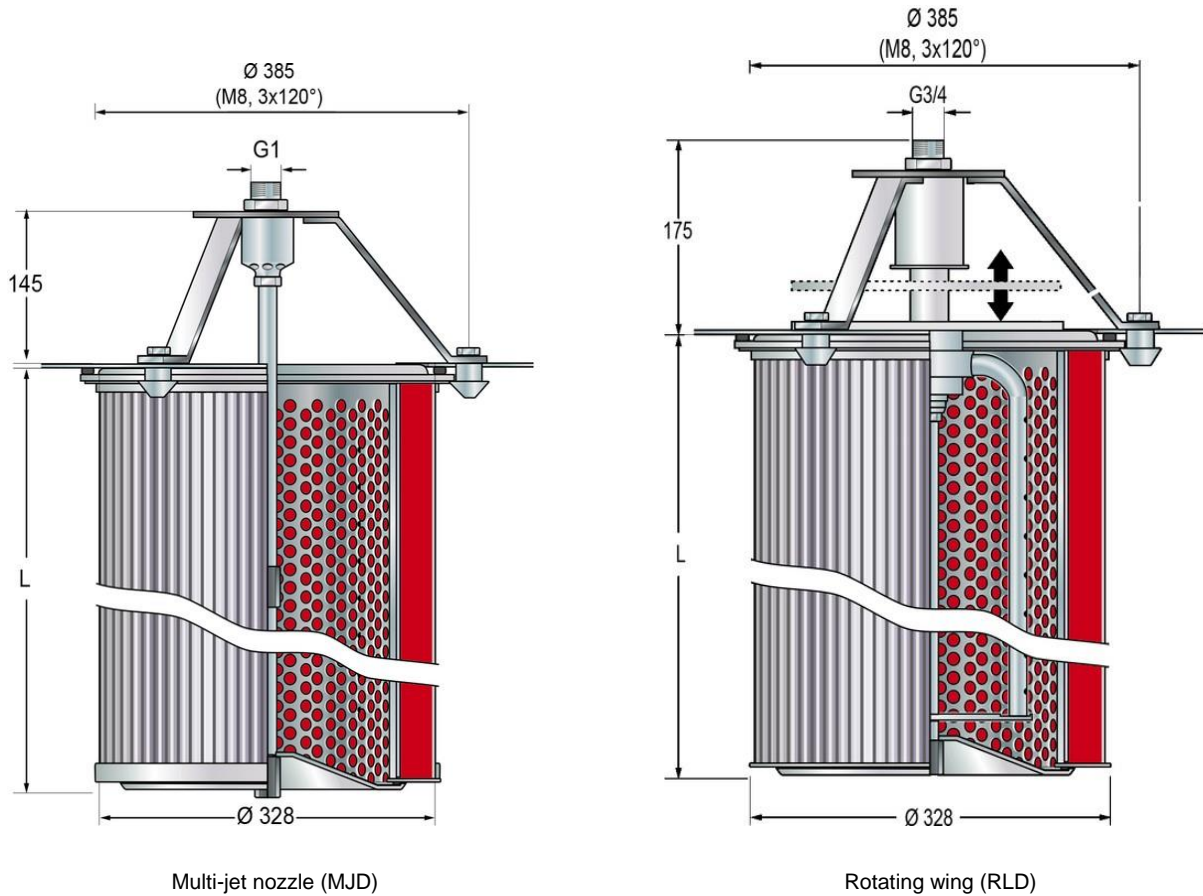

Multi-jet nozzle (MJD)

Rotating wing (RLD)

5. Accessories

Order number	Designation
76161913	Reusable end cap, galvanized steel
76161921	Reusable end cap, stainless steel V4A - AISI 316
77838568	Centre ring-EL 033, galvanized steel
77934326	Centre ring-EL 033, stainless steel V2A - AISI 304
77885031	Centre ring-2E 033, galvanized steel
78215220	Centre ring-2E 033, stainless steel V2A - AISI 304
79791104	Holding bolts PA6, pack of 3
79356387	Cleaning unit MJD-32 06 ROH A1
78331852	Cleaning unit RLD-32 06 ROH A1
79339219	Cleaning unit RLD-32 06 ROH V2
78296840	Cleaning unit RLD-32 06 ROH V1

6. Cleaning

Two cleaning systems are available for dust filter cartridges with a diameter of 328 mm



Filtration Group multi-jet nozzle (MJD)

The optimised geometry of the multi-jet nozzle guarantees excellent cleaning results with a significantly lower noise level. The multi-jet nozzle is available from Filtration Group in aluminium or stainless steel. It can also be purchased as part of the Filtration Group MJD cleaning unit, comprising the nozzle, a tripod and various small assembly components. The tripod maintains an optimum distance from the cartridge to ensure maximum cleaning efficiency.

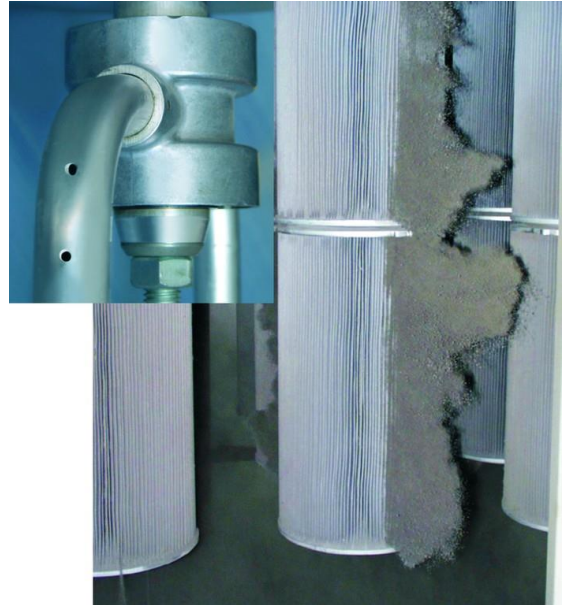

Filtration Group rotating wing (RLD)

The baffle plate closes during cleaning and the rotating wing begins to turn. The large number of pulsed air jets that are discharged from the wing elements guarantee gentle, uniform cleaning over the complete cartridge length. The simultaneous vibratory movement in the pleats generates a significant improvement in cleaning efficiency, particularly with critical dusts. Each pleat is cleaned several times. The filter life is optimised as a result of the rotating wing.

7. Design

Please contact us for detailed technical information, any open questions and for general expert advice. Completion of the relevant questionnaire would facilitate in the coordination of all important parameters.

Comprehensive documentation on our product range, cleaning units and cartridges can be provided.

Filtration Group GmbH
Schleifbachweg 45
D-74613 Öhringen
Phone +49 7941 6466-0
Fax +49 7941 6466-429
industrial.sales@filtrationgroup.com
industrial.filtrationgroup.com
70342676.04/2020
[Dust filter cartridge 328 NZ](#)